

Vortex Flow Meter

LUGB-D series

LUGB-V series



Description

The vortex flowmeter is used for measuring the flow velocity of gases or liquids in pipelines flowing full. The measuring principle is based on the development of a Karman vortex shedding street in the wake of a body built into the pipeline. The periodic shedding of eddies occurs first from one side and then from the other side of a bluff body (vortex-shedding body) installed perpendicular to the pipe axis. Vortex shedding generates a so-called "Karman vortex street" with alternating pressure conditions whose frequency is proportional to the flow velocity.

Application Range	(1) Gas; (2) Liquid;(3) Steam
Measured Value	
Primary Measured Value	Flow Rate
Secondary Measured Value	Volume flow(Pressure and Temperature is available)
Temperature	
Process Temperature	T1 Level: -20...+100°C T2 Level: -20...+250°C T3 Level: -20...+350°C
Ambient Temperature	-10...+70°C
Pressure	
EN 1092-1	DN200...DN300: PN10 DN100...DN200: PN16 DN15...DN80: PN25 Other pressure on request
ASME B16.5	1/2"...8": 150 lb RF Other pressure on request
JIS	1/2"...8": 10K Other pressure on request
Reference Condition	Flow conditions similar to EN 29104 Medium: Water/ Gas/ Steam Electrical Conductivity:≥300μS/cm Temperature: -10...+30°C Inlet Section:≥10DN Operating pressure: 1 bar/ 14.5 PSIG
Accuracy	For Liquid: ±1.0% of rate For Gas and Steam: ±1.5% of rate
Body Material	SS304 SS316
Converter Material	Standard: Polyurethane coated die-cast aluminum

Model Selection

Model	Suffix Code								Description
LUGB-	①	②	③	④	⑤	⑥	⑦	⑧	Vortex Flowmeter
Fluid	L								Liquid
	G								Gas / Air
	S								Steam
Diameter		XXX							Stand for diameter 015: DN15; 050: DN50 100: DN100; 300: DN300
Structure			S						Compact type
			L						Remote type
Converter Type				N					24V DC; Pulse output; No display; Ex
				A					24V DC; 4-20mA output; No display; Ex
				B					Battery power supply; No output; Ex
				C					24V DC; 4-20mA / Pulse output
				V					24V DC; 4-20mA/ Pulse output (V type is only for Gas/ Steam application)
				D					24V DC; 3-wire 4-20mA output; Temperature & Pressure Compensation
				Notice:					1) Modbus RS485 is optional for C, V, D series 2) Dual power (24V DC +Battery) is optional for C, V, D series
Body Material					S4				SS304
					S6				SS316
Explosion Proof						BT			ExdIIBT6
						CT			ExibIICT4
						NA			No explosion proof
Connection							WAF		Wafer connection
							DXX		D16: DIN PN16 Flange; D25: DIN PN25 Flange...
							AXX		A15: ANSI 150# Flange; A30: ANSI 300 # Flange...
							JXX		J10: JIS 10K Flange; J20: JIS 20K Flange...
Temperature								T1	-20...+100°C
								T2	-20...+250°C
								T3	-20...+350°C

Example:

LUGB ^①S ^②100 ^③S ^④D ^⑤S4 ^⑥CT ^⑦D16 ^⑧T2

- ① S: Steam application
- ② 100: DN100
- ③ S: Compact type with local display
- ④ D: 24V DC power supply; temperature and pressure compensation
- ⑤ S4: SS304 body material
- ⑥ CT: ExibIICT4
- ⑦ D16: Flange DIN PN16
- ⑧ T2: -20...+250°C



Flow Range

Diameter		Liquid	Gas
(mm)	(Inch)	Flow (m ³ /h)	Flow (m ³ /h)
15	1/2"	1.2 to 6.2	5 to 25
20	3/4"	1.5 to 10	8 to 50
25	1"	1.6 to 16	10 to 70
40	1-1/2"	2.5 to 26	22 to 220
50	2"	3.5 to 38	36 to 320
65	2-1/2"	6.2 to 65	50 to 480
80	3"	10 to 100	70 to 640
100	4"	15 to 150	130 to 1100
125	5"	25 to 250	200 to 1700
150	6"	36 to 380	280 to 2240
200	8"	62 to 650	580 to 4960
250	10"	140 to 1400	970 to 8000
300	12"	200 to 2000	1380 to 11000

Notice: The flow range as above is for reference only. Consult the factory if you have special requirement. Refer to the nameplate or certificate for actual flow range.

Dimensions

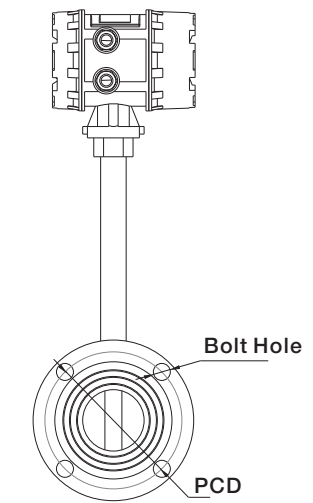
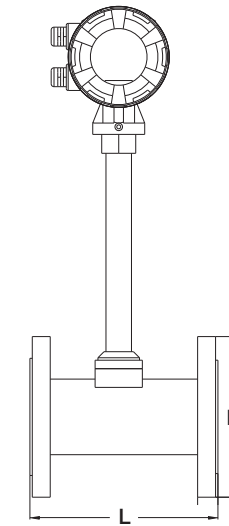

DIN Flange Meter Dimension

Size Code		L	DIN Flange Pressure Rating	Flange Diameter (B)	Bolt Hole Diameter	Bolt Circle Diameter (PCD)	Bolt Hole Quantity
(Inch)	(mm)	(mm)	Mpa	(mm)	(mm)	(mm)	
1/2"	15	180	1.6	95	14	65	4
3/4"	20	180	1.6	105	14	75	4
1"	25	180	1.6	115	14	85	4
1-1/4"	32	180	1.6	140	18	100	4
1-1/2"	40	180	1.6	150	18	110	4
2"	50	180	1.6	165	18	125	4
2-1/2"	65	200	1.6	185	18	145	4
3"	80	200	1.6	200	18	160	8
4"	100	200	1.6	220	18	180	8
5"	125	220	1.6	250	18	210	8
6"	150	220	1.6	285	22	240	8
8"	200	220	1.6	340	22	295	12
10"	250	250	1.6	405	26	355	12
12"	300	300	1.6	460	26	410	12